

BHTS 2RS C3 VT 180°

Łożyska wysokotemperaturowe



6000 SERIA

Oznaczenie	S.we. (B)	S.ze. (D)	S-ość.. (W)	Pr-ość. OBR./MIN	Obci.statyc. kN na 180°C	Obci.statyc. kN na 20°C
6000 BHTS 2RS C3 VT 180°	10	26	8	6600	1,76	1,96
6001 BHTS 2RS C3 VT 180°	12	28	8	6380	2,10	2,36
6002 BHTS 2RS C3 VT 180°	15	32	9	6160	2,50	2,85
6003 BHTS 2RS C3 VT 180°	17	35	10	5940	2,90	3,25
6004 BHTS 2RS C3 VT 180°	20	42	12	5720	4,50	5,00
6005 BHTS 2RS C3 VT 180°	25	47	12	5280	5,20	5,85
6006 BHTS 2RS C3 VT 180°	30	55	13	4840	7,20	8,00
6007 BHTS 2RS C3 VT 180°	35	62	14	4400	9,30	10,4
6008 BHTS 2RS C3 VT 180°	40	68	15	3960	10,6	11,8
6009 BHTS 2RS C3 VT 180°	45	75	16	3520	12,8	14,3
6010 BHTS 2RS C3 VT 180°	50	80	16	3080	14,0	15,6

6200 SERIA

Oznaczenie	S.we. (B)	S.ze. (D)	S-ość.. (W)	Pr-ość. OBR./MIN	Obci.statyc. kN na 180°C	Obci.statyc. kN na 20°C
6200 BHTS 2RS C3 VT 180°	10	30	9	6380	2,3	2,60
6201 BHTS 2RS C3 VT 180°	12	32	10	6160	2,8	3,10
6202 BHTS 2RS C3 VT 180°	15	35	11	5940	3,3	3,75
6203 BHTS 2RS C3 VT 180°	17	40	12	5720	4,2	4,75
6204 BHTS 2RS C3 VT 180°	20	47	14	5280	5,9	6,55
6205 BHTS 2RS C3 VT 180°	25	52	15	4840	7,2	8,00
6206 BHTS 2RS C3 VT 180°	30	62	16	4400	10,0	11,2
6207 BHTS 2RS C3 VT 180°	35	72	17	3960	13,7	15,3
6208 BHTS 2RS C3 VT 180°	40	80	18	3520	16,2	18,0
6209 BHTS 2RS C3 VT 180°	45	85	19	3080	18,3	20,4
6210 BHTS 2RS C3 VT 180°	50	90	20	2640	21,6	24,0

6300 SERIA

Oznaczenie	S.we. (B)	S.ze. (D)	S-ość.. (W)	Pr-ość. OBR./MIN	Obci.statyc. kN na 180°C	Obci.statyc. kN na 20°C
6300 BHTS 2RS C3 VT 180°	10	35	11	6160	3,1	3,45
6301 BHTS 2RS C3 VT 180°	12	37	12	5940	3,7	4,15
6302 BHTS 2RS C3 VT 180°	15	42	13	5720	4,8	5,40
6303 BHTS 2RS C3 VT 180°	17	47	14	5280	5,8	6,55
6304 BHTS 2RS C3 VT 180°	20	52	15	4840	7,6	8,50
6305 BHTS 2RS C3 VT 180°	25	62	17	4400	10,2	11,4
6306 BHTS 2RS C3 VT 180°	30	72	19	3960	14,6	16,3
6307 BHTS 2RS C3 VT 180°	35	80	21	3520	17,1	19,0
6308 BHTS 2RS C3 VT 180°	40	90	23	3080	22,5	25,0
6309 BHTS 2RS C3 VT 180°	45	100	25	2640	28,8	32,0
6310 BHTS 2RS C3 VT 180°	50	110	27	2200	34,2	38,0

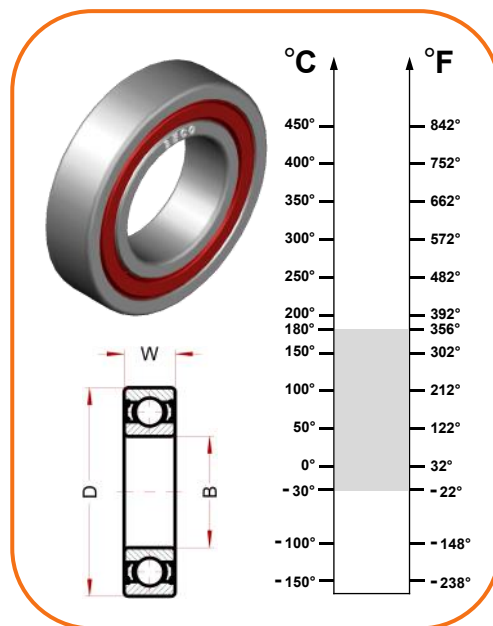

Charakterystyka techniczna:

- Materiał łożyska: stal AISI 52100 (Stal chromowa) stabilizowana cieplnie
- Luz promieniowy C3
- Uszczelnienie 2RS, stalowa blaszka zwulkanizowana z Vitonem do 250°C
- Nasmarowane dożywnotnio smarem dla temperatur do 200°C
- Nie wymaga dodatkowego smarowania

Zastosowanie:

- Przenośniki powietrzne
- Sprężarki suche
- Wentylatory przemysłowe
- Maszyny pakujące
- Przemysł papierniczy

BECCO

12100 Cuneo - Italy
 phone: 0039 0171 66883
 mail: office@becoitalia.biz
 www.becoitalia.biz



in Poland