

# BHTS ZZ FB 375°

Beco Plus



## Łożyska do ekstremalnych temperatur

6200 SERIA

Oznaczenie	S.we. (B)	S.ze. (D)	S-ość. (W)	Pr-ość. OBR./MIN	Obci.statyc. kN na 375°C	Obci.statyc. kN na 20°C
6200 BHTS ZZ FB 375° Beco Plus	10	30	9	90	1,79	3,12
6201 BHTS ZZ FB 375° Beco Plus	12	32	10	85	2,14	3,72
6202 BHTS ZZ FB 375° Beco Plus	15	35	11	80	2,59	4,50
6203 BHTS ZZ FB 375° Beco Plus	17	40	12	75	3,28	5,70
6204 BHTS ZZ FB 375° Beco Plus	20	47	14	70	4,52	7,86
6205 BHTS ZZ FB 375° Beco Plus	25	52	15	65	5,52	9,60
6206 BHTS ZZ FB 375° Beco Plus	30	62	16	60	7,72	13,44
6207 BHTS ZZ FB 375° Beco Plus	35	72	17	55	10,55	18,36
6208 BHTS ZZ FB 375° Beco Plus	40	80	18	50	12,41	21,60

6300 SERIA

Oznaczenie	S.we. (B)	S.ze. (D)	S-ość. (W)	Pr-ość. OBR./MIN	Obci.statyc. kN na 375°C	Obci.statyc. kN na 20°C
6300 BHTS ZZ FB 375° Beco Plus	10	35	11	90	2,38	4,14
6301 BHTS ZZ FB 375° Beco Plus	12	37	12	85	2,86	4,98
6302 BHTS ZZ FB 375° Beco Plus	15	42	13	80	3,72	6,48
6303 BHTS ZZ FB 375° Beco Plus	17	47	14	75	4,52	7,86
6304 BHTS ZZ FB 375° Beco Plus	20	52	15	70	5,86	10,2
6305 BHTS ZZ FB 375° Beco Plus	25	62	17	65	11,24	13,68
6306 BHTS ZZ FB 375° Beco Plus	30	72	19	60	13,10	19,56
6307 BHTS ZZ FB 375° Beco Plus	35	80	21	55	16,53	22,80
6308 BHTS ZZ FB 375° Beco Plus	40	90	23	50	17,20	30,00
6309 BHTS ZZ FB 375° Beco Plus	45	100	25	45	22,00	38,40
6310 BHTS ZZ FB 375° Beco Plus	50	110	27	40	26,20	45,60

### DOSTĘPNE NA ZAPYTANIE:

6000 SERIA

Oznaczenie	S.we. (B)	S.ze. (D)	S-ość. (W)	Pr-ość. OBR./MIN	Obci.statyc. kN na 375°C	Obci.statyc. kN na 20°C
6000 BHTS ZZ FB 375° Beco Plus	10	26	8	90	1,35	2,35
6001 BHTS ZZ FB 375° Beco Plus	12	28	8	85	1,63	2,83
6002 BHTS ZZ FB 375° Beco Plus	15	32	9	80	1,97	3,42
6003 BHTS ZZ FB 375° Beco Plus	17	35	10	75	2,24	3,90
6004 BHTS ZZ FB 375° Beco Plus	20	42	12	70	3,45	6,00
6005 BHTS ZZ FB 375° Beco Plus	25	47	12	65	4,03	7,02
6006 BHTS ZZ FB 375° Beco Plus	30	55	13	60	5,52	9,60
6007 BHTS ZZ FB 375° Beco Plus	35	62	14	55	7,17	12,48
6008 BHTS ZZ FB 375° Beco Plus	40	68	15	50	8,14	14,16
6009 BHTS ZZ FB 375° Beco Plus	45	75	16	45	9,86	17,16
6010 BHTS ZZ FB 375° Beco Plus	50	80	16	40	10,76	18,72

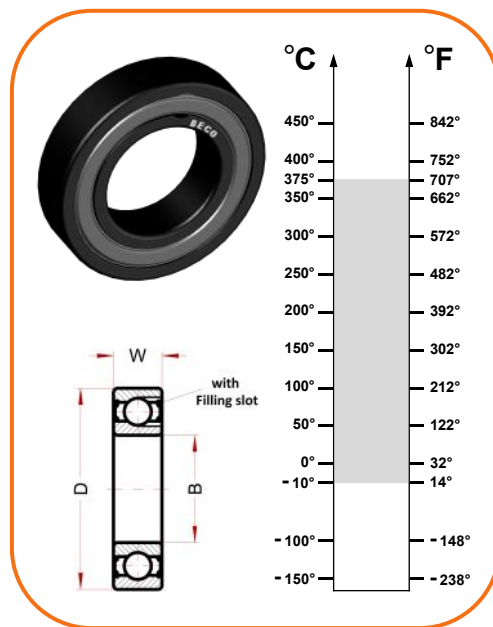

### Charakterystyka techniczna:

- Materiał łożyska: stal AISI 52100 (Stal chromowa) stabilizowana cieplnie
- Pokrycie powłoką fosforanu manganu wszystkich elementów łożyska
- Luz promieniowy 4xC5
- Blaszki ochronne typu ZZ
- Nasmarowane dożywno smarem złożonym BECO dla temperatury do 375°C
- Nie wymaga dodatkowego smarowania

### Zastosowanie:

- Piece malarskie
- Przemysł stalowy
- Paleniska dla przemysłu ceramicznego
- Wózki przemysłowe, Wózki dla cegielni

# BECCO

12100 Cuneo - Italy  
 phone: 0039 0171 66883  
 mail: office@becoitalia.biz  
 www.becoitalia.biz



in Poland