



**SNR thermoplastic
self-aligning bearing units**

SNR - Industry



Contents

1. General	
SNR, a self-aligning product range	P.3
Assistance	P.4
Self-aligning bearing units interchange	P.5
2. Properties of thermoplastic self-aligning bearing units	
Applications	P.7
Capabilities	P.7 - 9
Characteristic properties of PBT	P.10
Chemical resistance of PBT	P.11
3. Insert bearings	
Series and dimensions	P.12
Lubrication	P.12
4. Installation of bearing units	
Fitting precautions	P.14
Screw tightening torque for thermoplastic bearing units	P.14
Permissible misalignments	P.15
Description of the installation steps	P.16
Accessories	P.17
5. Designations and characteristics	
Thermoplastic self-aligning bearing units	P.18 - 23
Stainless steel insert bearings (inch)	P.24 - 25
Stainless steel insert bearings (metric)	P.26
Open and closed endcaps	P.27



Our bearing units align themselves with all your expectations

Self-aligning bearings are used in extremely diverse industrial applications. Their very design principle subjects them to high stress situations where perfect alignment is not guaranteed. However misalignment is not the only stress that this type of product might have to face: high speeds of rotation, vibration, corrosion and contamination can be severely taxing. It is therefore vital for the bearing material and technology to be perfectly suited to the application. This is why we have developed the range:

Thermoplastic self-aligning units and stainless steel insert bearings to withstand corrosion.

All our products have certain points in common:

- *they are easily and rapidly installed,*
 - *their design takes into account your productivity and maintenance objectives,*
 - *lastly, they are of irreproachable quality.*
- Through its experience in the industrial and automotive sectors, SNR has acquired in-depth knowledge in this area: choice of materials, internal geometry, lubrication, etc.*

The range:

Thermoplastic self-aligning bearing units and stainless steel insert bearings to withstand corrosion.

Part number	Bore		Type of housing
	MUC 2.. FD	MUC 2..-.. FD	
GNP	20 to 40 mm	5/8 to 1 1/2	 <p>GNP</p>
GSF	20 to 40 mm	5/8 to 1 1/2	 <p>GSF</p>
GSFT	20 to 40 mm	5/8 to 1 1/2	 <p>GSFT</p>

- Flat base: preventing objectionable dirt, mold or bacteria.
- Stainless steel grease nipple.
- Stainless steel sleeves for fixing bolts: higher reliability, corrosion resistant.
- Food-grade grease, so no risk for food products.
- Endcaps open or closed for additional protection.



Assistance

Our experience is the best guarantee of product longevity

Partnering with the major groups in the aeronautical and automotive manufacturing industries, we consider that informing our customers is an integral part of our professional role. This of course holds true for our self-aligning bearing units: the SNR advisors will give you the best technical recommendations for your needs. They are also ready to come to your site to assist in installation, removal or maintenance operations.

They will verify the selection is appropriate for the application, the condition of the bearings, the installation procedures, etc., and ensure a bearing service life that complies with the application specifications.

Self-aligning bearing units interchange

Thermoplastic self-aligning bearing units

Part number Stainless steel bearings



SNR	MUC..FD		GNP..	GSF..	GSFT..
SKF	YAR 2..-2RF/HVGFA		SYK..TH/GFA	FYK..TH/GFA	FYTBK..TH/GFA
INA	GYE..KRRB VA		RASEY..TN VA	RCJY..TN VA	RCJTY..TN VA
NSK-RHP	PNP..CR		PNP..CR	PSF..CR	PSFT..CR
NTN	F-UC2..D1/LP03		F-UCPR2../LP03	...	F-UCFLR2../LP03
AMI	MUC...		MUCPPL...	MUCFPL...	MUCNFL...
MRC	RRH..BRR		CPB..SS	C4F..SS	C2F..SS

This interchange table is for guide purposes only. Please consult the manufacturer catalogue for more detailed information.



Bacteria and corrosion cannot affect them

*The housings of SNR thermoplastic self-aligning bearing units are made of white PBT resins and **have a smooth surface that prevents the retention of dust, mold and bacteria.** No additional surface coating is required. The design of our products, and the quality of the resins used, are two determining factors in combating bacterial attack. The bearings have*

stainless steel rings and balls, and are lubricated with food-grade grease.

The bearing units are available as pillow blocks and two or four-bolt flanges. They are equipped with stainless steel inserts to reinforce the attachment of the screws and lubricator.

Exceptional resistance:

• to chemical agents:

Our bearings display excellent resistance to a wide range of chemicals: acids, bases, organic solvents, salts, etc. The user must nevertheless evaluate each application depending on the exposure to possible combinations of chemical products and particular environmental conditions (see tables page 10 and 11).

• to high temperatures:

Our bearing units can operate at temperatures ranging from -4°F to $+230^{\circ}\text{F}$ without any problem. The tensile strength of PBT resins varies according to temperature. The resistance

of the bearing unit housings has to be adjusted according to the service temperature, using operating at 68°F as a reference. For example, the resistance of a bearing unit operating at 105°F is 0.75 times the one given for a temperature of 68°F .

Notice: The resistance of bearing unit housings does not depend solely on the ambient temperature but above all on the operating temperature, which is itself dependent on the ambient temperature, the bearing unit load and the rotational speed of the parts. When rotation speeds are high, it is not uncommon for the operating temperature to exceed 140°F .

Applications

Food processing, pharmaceutical and chemical industries

The anti-corrosion properties of our thermoplastic bearing units mean they can be used in numerous industries for diverse applications in wet or

chemical environments, or under conditions necessitating frequent washing with large quantities of water.

Examples: bottling lines, food or medication production lines, etc.

Capabilities

The SNR thermoplastic self-aligning bearing units are more specifically designed for applications that are subject to strict hygiene

standards. They are resistant to corrosion, heat and chemical products. (Refer to the following tables).

Properties of SNR thermoplastic self-aligning bearing units



Capabilities of SNR thermoplastic self-aligning bearing units

Speeds, radial and axial loads - GNP series

Part number	Maximum speed of rotation	Directions of radial and axial loads on housings	Maximum static radial load of bearings C_o	Maximum capacity of housing at 20 °C under continuous load	Maximum axial load with bearing retention by set-screws	Screw size		
	rpm			x 1,000 Newtons				
	Shaft tolerance h6			↓	↑	←	↔	
GNP 20	7,400		5.30	1.70	1.40	1.30	0.70	M10
GNP 25	6,200	6.30	2.00	1.50	1.30	0.90	M10	
GNP 30	5,300	9.00	2.50	1.80	2.00	1.30	M10	
GNP 35	4,500	12.30	3.00	2.10	2.10	1.60	M12	
GNP 40	4,000	14.30	3.00	2.10	2.10	1.60	M12	

Speeds, radial and axial loads - GSF series

Part number	Maximum speed of rotation	Directions of radial and axial loads on housings	Maximum static radial load of bearings C_o	Maximum capacity of housing at 20 °C under continuous load	Maximum axial load with bearing retention by set-screws	Screw size
	rpm			x 1,000 Newtons		
	Shaft tolerance h6			↓	↔	
GSF 20	7,400		5.30	1.60	0.70	M10
GSF 25	6,200	6.30	1.70	0.70	M10	
GSF 30	5,300	9.00	2.30	1.10	M10	
GSF 35	4,500	12.30	3.10	1.30	M12	
GSF 40	4,000	14.30	3.10	1.50	M12	

Speeds, radial and axial loads - GSFT series

Part number	Maximum speed of rotation	Directions of radial and axial loads on housings	Maximum static radial load of bearings C_o	Maximum capacity of housing at 20 °C under continuous load			Screw size
	rpm			x 1,000 Newtons			
	Shaft tolerance h6			←	↓	↔	
GSFT 20	7,400		5.30	2.20	0.90	0.70	M10
GSFT 25	6,200		6.30	2.20	1.50	0.70	M10
GSFT 30	5,300		9.00	2.90	1.60	1.00	M10
GSFT 35	4,500		12.30	3.20	2.00	1.40	M12
GSFT 40	4,000		14.30	3.20	2.00	1.40	M12

Properties of SNR thermoplastic self-aligning bearing units



Characteristic properties of PBT

Properties	Unit	Test method	
Mechanical			
Tensile strength at yield	N/mm ²	ASTM D 638	115
at break	N/mm ²	ASTM D 638	-
Elongation at yield	%	ASTM D 638	3
at break	%	ASTM D 638	-
Tensile modulus	N/mm ²	ASTM D 638	8,000
Flexural yield strength	N/mm ²	ASTM D 790	170
Flexural modulus	N/mm ²	ASTM D 790	7,000
Notched impact strength Charpy	k/m ²	DIN 53453	12
Notched impact strength IZOD	J/m	ASTM D 256	100
Hardness H358/10	N/mm ²	DIN 53456	104
Hardness H358/60	N/mm ²	DIN 53456	101
Hardness Rockwell	-	ASTM D 785	L 102
Thermal			
Oxygen index	%	ASTM D 2863	19
Flame retardancy (1/6 mm thickness)	-	UL stand 94	94HB
Heat resistance : Vicat, method B	°C	ASTM D 1525	210-215
Thermal conductivity	W/m ² C	ASTM C 177	0.19
Mould shrinkage flow	%	ASTM D 1299	0.4-0.6
Cross flow direction	%	ASTM D 1299	0.6-0.8
Physical			
Water absorption		ASTM D 570	
Saturation for 24 h, at 23 °C	%		0.06

Chemical resistance of PBT

All data expressed in terms of % retention of tensile strength.

Chemical media	°C	Immulsion days	% retention of strength
Acids			
10 % Hydrochloric	23	30	89
	23	90	85
	23	180	82
10 % Sulfuric	23	30	97
	23	90	94
	23	180	90
36 % Sulfuric (battery)	23	30	97
	23	180	96
	66	30	84
	66	180	35
10 % Acetic	23	30	89
	23	180	88
Bases			
5 % Potassium Hydroxyde	23	30	83
	23	90	10
10 % Sodium Hydroxyde	23	30	2
	23	180	-
10 % Ammonium Hydroxyde	23	30	90
	23	90	87
	23	180	58
Salts			
10 % Zinc Chloride	25	30	97
	25	90	94
10 % Calcium Chloride	25	30	98
	25	90	98
5 % Sodium Chloride	25	30	97
	25	90	97
Organic solvents			
Ethyl Alcohol	23	30	99
	23	180	94
Methyl Alcohol	23	30	91
	23	180	76
Isopropyl-Alcohol	23	30	100
	23	180	100
Isopropyl-Alcohol & Water (50/50)	23	30	93
	23	180	96
Turpentine	23	30	66
	23	180	92
Acetone	23	30	90
	23	180	63

SNR insert bearings



Series and dimensions

“Metric” Series

MUC 204 FD
MUC 205 FD
MUC 206 FD
MUC 207 FD
MUC 208 FD

“Inch” Series

MUC 202-10 FD
MUC 204-12 FD
MUC 205-16 FD
MUC 206-18 FD
MUC 206-19 FD
MUC 206-20 FD
MUC 207-20 FD
MUC 207-22 FD
MUC 207-23 FD
MUC 208-24 FD

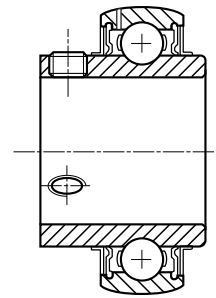

The insert bearings for thermoplastic self-aligning bearing units are made from stainless steel with the necessary qualities to resist corrosion and chemical and bacterial attack. They are of the single-row radial-contact ball type, with a wide inner ring that protrudes

on both sides with a set-screw retention system.

Our bearing are also available for aftermarket. They are then packed and delivered in unit boxes.

Lubrication

The bearings are supplied pre-greased with a food-grade grease made from a paraffin mineral oil and an odorless insipid aluminum complex that satisfies the requirements 21 CFR 178 357 of the US Food and Drug Administration (FDA). This grease is classified H1 in accordance with the recommendations of the USDA

(United States Department of Agriculture). Grade NLGI 2.

It therefore presents no risks for food products that might come into contact with the bearing units.



Installation of the bearing units



Priority for simplicity

Fitting precautions

Before installing the bearing units, check the cleanliness and flatness of the seating surfaces, essential conditions to ensure optimal hygiene. Install the shaft, attaching the bearing unit housings to the supporting frame. Tighten the screws of the bearing inner ring to the required torque.

Whatever the type of bearing, make sure that the shaft

- can be rotated by hand without any abnormal radial or axial stress,
- is not distorted, as this would lead, through rotational deflection, to constant swivelling of the bearing outer rings in their housing.

Screw tightening torque for thermoplastic bearing units

The retention screws are of stainless steel and can break if tightened excessively.

Do not exceed the maximum tightening torque indicated below.

Basic bearing reference number	Screw size	Allen wrench A/F dimensions	Maximum tightening torque applicable to screws
	mm	mm	N.m
MUC 204 FD ~ 206 FD	M6 x 1	3	3.9
MUC 207 FD ~ 208 FD	M8 x 1	4	8.3

Permissible misalignments

- With provision for re-lubrication, the bearing can swivel inside the housing up to an angle α of about 5° (the groove is aligned with the lubricator hole) and 8° without provision for re-lubrication.

- **Pay attention to the swiveling of the bearing in the bearing unit.** Permanent swiveling induced by rotational deflection of the shaft would cause wear of the housing and is therefore not permissible (angle β).

- The maximum permissible values are those for deep-groove ball bearings corresponding to the same shaft diameter (maximum angle $\beta < 0.5^\circ$).

Example:

MUC 204 FD \Leftrightarrow shaft diameter of 20 mm \Leftrightarrow 6204

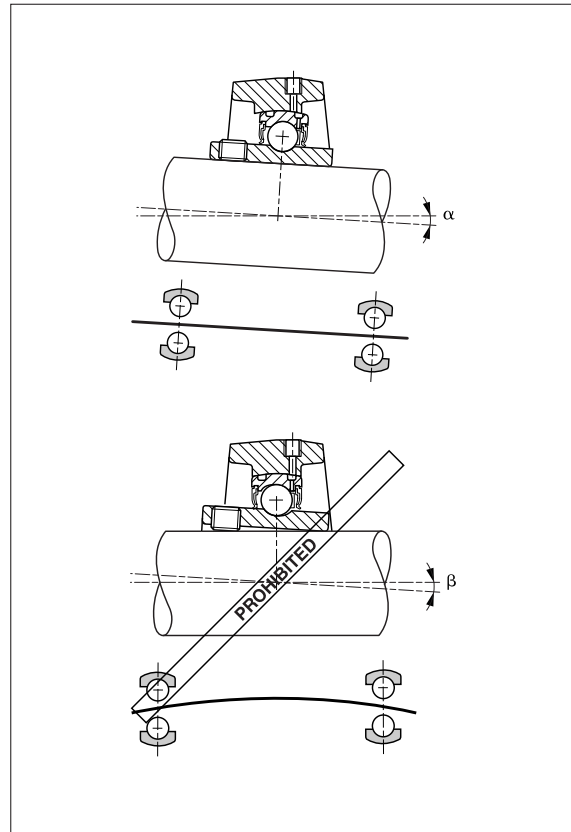

Installation of the bearing units



Description of the installation steps

Self-aligning bearing units must be installed under conditions that ensure maximum bearing life. We recommend that you refer to the following chapters and follow the reference procedures for this type of bearing unit.

When installing sealed bearings, grease the seals to avoid dry operation when the shaft first starts to rotate.

Make sure that the seating surfaces are perfectly clean and flat before starting any installation operations.



Install the shaft by mounting the bearing unit housings on the supporting frame. Tighten the inner ring retaining screw to the required torque indicated in the torque value table. (see page 14)

In all cases the shaft is installed first by attaching the bearing unit housings to the supporting frame. Tighten the screws in alternate diagonals.



Installation / removal of protective covers

The covers are installed by snap-fitting, which can be done with a light blow of a mallet.

They are removed by inserting the tip of a screwdriver into the cavity and applying outward pressure to release them.



Accessories

Endcaps for thermoplastic bearing units are attached to the housing. They ensure compliance with certain safety standards or can provide additional protection for the bearing unit when the environmental conditions are particularly severe.

They are made of white SR 50 polypropylene. Available in two versions, open or closed.

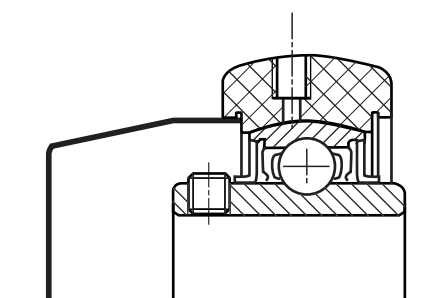

GNP (metric)

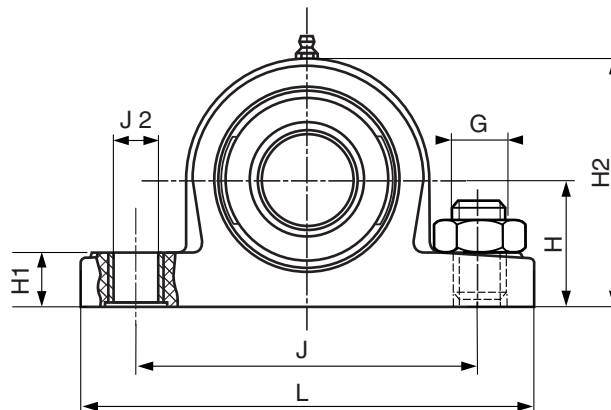

Part number		Dimensions (mm)						
Bearing units	Bearings	Bore d	L	H	H1	H2	J	J1
GNP20	MUC 204 FD	20	127.0	33.30	14.2	65.0	95.0	11.0
GNP25	MUC 205 FD	25	140.0	36.50	14.5	71.0	105.0	11.0
GNP30	MUC 206 FD	30	162.0	42.90	17.8	83.0	119.0	14.0
GNP35	MUC 207 FD	35	167.0	47.60	18.0	94.0	127.0	14.0
GNP40	MUC 208 FD	40	184.0	49.20	19.5	98.0	137.0	14.0

Nota bene: "inch series" insert bearing can be delivered upon request.

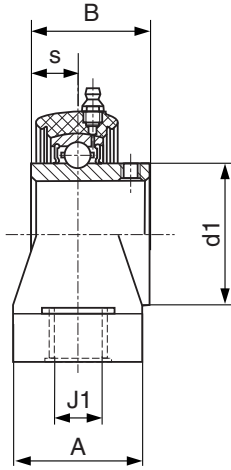

Dimensions (mm)						Basic load rating x 1,000 Newtons	Limiting speed	Weight
J2	G	A	B	s	d1	C ₀ Static	rpm	kg
14.0	10	38.0	31.00	12.70	29.00	1.70	7,400	0.30
14.0	10	38.0	34.10	14.30	34.00	2.00	6,200	0.35
18.0	12	46.0	38.10	15.90	40.50	2.50	5,300	0.55
18.0	12	48.0	42.90	17.50	48.00	3.00	4,500	0.78
18.0	12	54.0	49.20	19.00	53.00	3.00	4,000	0.98

GSF (metric)

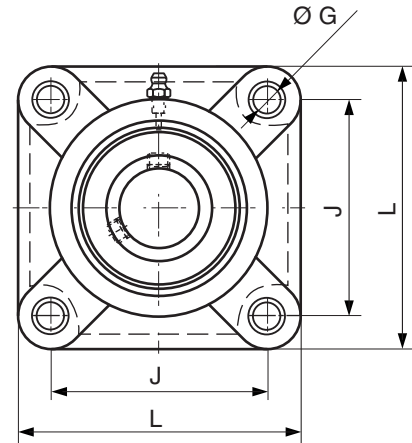

Part number		Dimensions (mm)					
Bearing units	Bearings	Bore d	L	J	G	A	A1
GSF20	MUC 204 FD	20	86	63.5	11	27.8	36.3
GSF25	MUC 205 FD	25	95	70.0	11	28.0	36.7
GSF30	MUC 206 FD	30	107	83.0	11	31.5	41.4
GSF35	MUC 207 FD	35	118	92.0	13	34.8	46.9
GSF40	MUC 208 FD	40	130	102.0	14	37.5	53.2

Nota bene: "inch series" insert bearing can be delivered upon request.

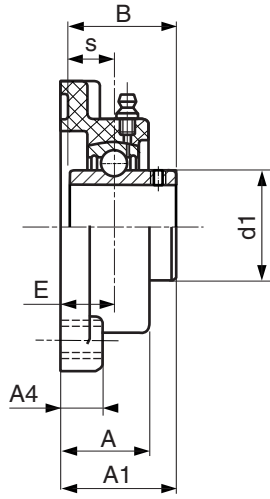

Dimensions (mm)					Basic load rating x 1,000 Newtons	Limiting speed	Weight
A4	E±IT 14	B	s	d1	C ₀ Static	rpm	kg
13.4	18.0	31.0	12.7	29.0	1.60	7,400	0.30
14.3	17.0	34.0	14.3	34.0	1.70	6,200	0.36
14.3	19.2	38.1	15.9	40.5	2.30	5,300	0.51
15.5	21.5	42.9	17.5	48.0	3.10	4,500	0.75
17.0	23.0	49.2	19.0	53.0	3.10	4,000	0.98

GSFT (metric)

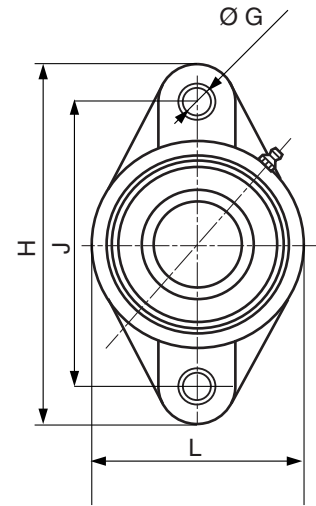

Part number		Dimensions (mm)						
Bearing units	Bearings	Bore d	L	H	J	G	A	A1
GSFT20	MUC 204 FD	20	64.8	130.0	90.0	11	26.50	33.70
GSFT25	MUC 205 FD	25	70.0	130.0	99.0	11	29.70	36.70
GSFT30	MUC 206 FD	30	80.0	148.0	117.0	11	30.50	41.20
GSFT35	MUC 207 FD	35	90.0	163.0	130.0	13	32.80	43.40
GSFT40	MUC 208 FD	40	100.0	175.0	144.0	14	37.50	51.70

Nota bene: "inch series" insert bearing can be delivered upon request.

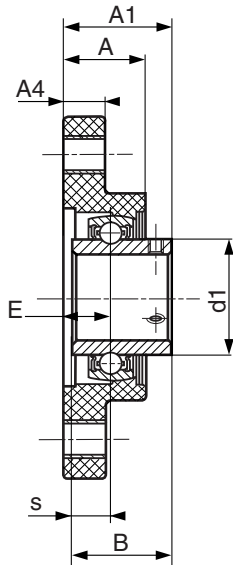

Dimensions (mm)					Basic load rating x 1,000 Newtons	Limiting speed	Weight
A4	E±IT 14	B	s	d1	C ₀ Static	rpm	kg
11.40	15.4	31.00	12.70	29.00	2.20	7,400	0.25
13.50	17.0	34.00	14.30	34.00	2.20	6,200	0.30
13.30	19.0	38.10	15.90	40.50	2.90	5,300	0.45
16.10	18.0	42.90	17.50	48.00	3.20	4,500	0.67
20.00	21.5	49.20	19.00	53.00	3.20	4,000	0.88

MUC (inch)

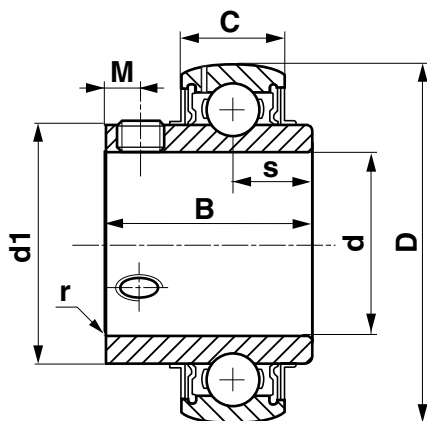

Part number	Dimensions									
	Bore d		D		C		B		s	
Bearings	in	mm	in	mm	in	mm	in	mm	in	mm
MUC 202-10 FD	5/8	15.875	1.850	47	0.669	17	1.220	31.00	0.500	12.7
MUC 204-12 FD	3/4	19.050	1.850	47	0.669	17	1.220	31.00	0.500	12.7
MUC 205-16 FD	1	25.400	2.047	52	0.669	17	1.339	34.10	0.563	14.3
MUC 206-18 FD	1-1/8	28.575	2.441	62	0.748	19	1.500	38.10	0.626	15.9
MUC 206-19 FD	1-3/16	30.162	2.441	62	0.748	19	1.500	38.10	0.626	15.9
MUC 206-20 FD	1-1/4	31.750	2.441	62	0.748	19	1.500	38.10	0.626	15.9
MUC 207-20 FD	1-1/4	31.750	2.835	72	0.787	20	1.689	42.90	0.689	17.5
MUC 207-22 FD	1-3/8	34.925	2.835	72	0.787	20	1.689	42.90	0.689	17.5
MUC 207-23 FD	1-7/16	36.512	2.835	72	0.787	20	1.689	42.90	0.689	17.5
MUC 208-24 FD	1-1/2	38.100	3.150	80	0.827	21	1.937	49.20	0.748	19.0

Dimensions						Basic load rating				Limiting speed	Weight	
d1		M		r		C		C ₀		rpm	lbs	kg
in	mm	in	mm	in	mm	dynamic lbf x 1,000 Newtons	dynamic lbf x 1,000 Newtons	static lbf x 1,000 Newtons	static lbf x 1,000 Newtons			
1.142	29.0	0.177	4.5	0.039	1.0	2,450	10.90	1,190	5.30	7,400	0.400	0.181
1.142	29.0	0.177	4.5	0.059	1.5	2,450	10.90	1,190	5.30	7,400	0.350	0.159
1.339	34.0	0.197	5.0	0.059	1.5	2,680	11.90	1,420	6.30	6,200	0.400	0.181
1.594	40.5	0.197	5.0	0.059	1.5	3,750	16.70	2,030	9.00	5,300	0.680	0.308
1.594	40.5	0.197	5.0	0.059	1.5	3,750	16.70	2,030	9.00	5,300	0.680	0.308
1.594	40.5	0.197	5.0	0.059	1.5	3,750	16.70	2,030	9.00	5,300	0.680	0.308
1.890	48.0	0.236	6.0	0.079	2.0	4,950	22.00	2,770	12.30	4,500	1.06	0.480
1.890	48.0	0.236	6.0	0.079	2.0	4,950	22.00	2,770	12.30	4,500	1.06	0.480
1.890	48.0	0.236	6.0	0.079	2.0	4,950	22.00	2,770	12.30	4,500	1.06	0.480
2.087	53.0	0.315	6.0	0.079	2.0	5,600	24.90	3,210	14.30	4,000	1.37	0.621

MUC (metric)

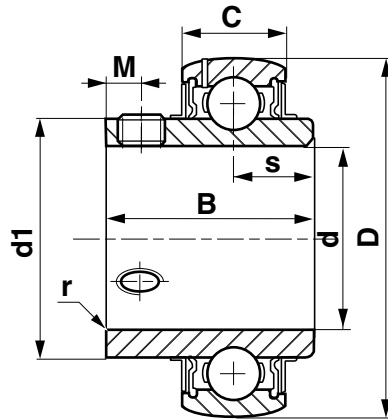

Part number	Dimensions (mm)									Basic load rating x 1,000 Newtons		Limiting speed rpm	Weight kg
	Bore d	D	C	B	s	d1	M	r	C Dynamic	C ₀ Static			
MUC 204 FD	20	47	17	31.00	12.70	29.00	4.50	1.5	10.90	5.30	7,400	0.16	
MUC 205 FD	25	52	17	34.10	14.30	34.00	5.00	1.5	11.90	6.30	6,200	0.19	
MUC 206 FD	30	62	19	38.10	15.90	40.50	5.00	1.5	16.70	9.00	5,300	0.31	
MUC 207 FD	35	72	20	42.90	17.50	48.00	6.00	2.0	22.00	12.30	4,500	0.48	
MUC 208 FD	40	80	21	49.20	19.00	53.00	8.00	2.0	24.90	14.30	4,000	0.62	

Endcaps for thermoplastic self-aligning bearing units

CF.. - CV..

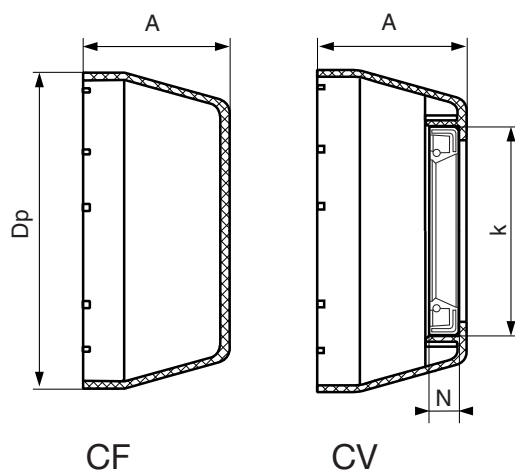

Endcaps	Part number		Bore		Dimensions (mm)			
	metric	Bearings inch	mm	d inch	Dp	A	N	k
CV 15	-	MUC 202-10 FD	15	5/8	50.1	23	7	32
CF 20 CV 20	MUC 204 FD	MUC 204-12 FD	20	3/4	50.1	23	7	32
CF 25 CV 25	MUC 205 FD	MUC 205-16 FD	25	1	55	25	7	37
CF 30 CV 30	MUC 206 FD	MUC 206-18 FD MUC 206-19 FD MUC 206-20 FD	30	1 1/8 1 3/16 1 1/4	64	30	7	42
CF 35 CV 35	MUC 207 FD	MUC 207-20 FD MUC 207-22 FD MUC 207-23 FD	35	1 1/4 1 3/8 1 7/16	74.5	32	7	47
CF 40 CV 40	MUC 208 FD	MUC 208-24 FD	40	1 1/2	84	37	7	52

Europe

FRANCE - EUROPE

SNR Paris 40, rue Jean Bleuzen
B.P. 49
92174 Vanves Cedex
Tél. 01 40 93 66 00
Fax. 01 40 93 66 10

SNR Logistique 9, avenue Léon Harmel
92160 Antony
Tél. 01 46 11 66 50
Fax. 01 46 11 66 66

SNR Bordeaux 1, rue du Golf - B.P. 173
33708 Merignac Cedex
Tél. 05 56 34 69 80
Fax. 05 56 34 69 81

SNR Lyon Europe* Le Florentin - 71, chemin
du Moulin Carron - B.P. 8
69570 Dardilly
Tél. 04 78 66 68 00
Fax. 04 78 66 68 20

SNR Nancy Europe* 3, allée Forêt de la Reine
Parc technologique Brabois
54500 Vandœuvre
Tél. 03 83 44 64 00
Fax. 03 83 44 02 31

DEUTSCHLAND

SNR WÄLZLAGER GMBH www.snr.de
40472 Düsseldorf Wahlerstraße 6
40437 Düsseldorf
Postfach 33 04 10
Tel. (0211) 6 58 06-0
Fax. (0211) 6 58 88 86

33719 Bielefeld Friedrich-Hagemann-Str.66
33701 Bielefeld
Postfach 17 01 45
Tel. (0521) 9 24 00-0
Fax. (0521) 9 24 00 90

70597 Stuttgart Tränkestraße 7
70574 Stuttgart
Postfach 70 04 16
Tel. (0711) 9 00 64-0
Fax. (0711) 9 00 64 99

ITALIA

SNR Italia Milano Via Keplero, 5
20019 Settimo
Milanese (MI)
Tel. (02) 33 55 21
Fax (02) 33 50 06 56

Bologna Via E.Zago, 2/2
40128 Bologna
Tel. (051) 36 79 46
(051) 36 29 78
Fax (051) 36 85 38

ESPAÑA - PORTUGAL

SNR Rodamientos Ibérica S.A.
Madrid C/ Llanos de Jerez, 22
Polígono Industrial
28820 Coslada
Tél. 91 671 89 13
Fax. 91 673 65 48

*EUROPE (Subsidiaries excepted)
SNR Nancy - Europe : Benelux - Suisse - Autriche - U.K.
SNR Lyon - Europe : Other Countries Fax. 04 78 66 68 21

Amériques / Americas

USA

SNR Bearings USA www.snrbearings.com
Atlanta 4600 K Highlands Pkwy
Smyrna, G.A. 30082
Tel. (770) 435-2818
(800) 232-1717
Fax. (800) 742-5215

AMERICA LATINA

SNR Argentina Buenos-Aires Viamonte 1145 - Piso 11
1053 Buenos-Aires
Tel. (54) 11-4 372-1272
Fax. (54) 11-4 372-0088

Autres pays / Other countries

SNR Intermondial (Overseas)

Anney 18, rue du Val-Vert
74600 Seynod
France
Tél. (33) 4 50 65 96 00/01/02
Fax. (33) 4 50 65 96 15

MAROC

SNR Maroc Casablanca 73, Bd Moulay Slimane
Ain Sebaâ CASABLANCA
B.P 15873 CASA-PRINCIPAL
e-mail : info@snr.ma
Tél. (212) 22 66 76 80
Fax. (212) 22 66 51 66



Siège social : Rue des Usines - 74000 Anney - FRANCE

RCS Anney B 325821072 - Code NAF 291H

<http://www.snr.fr>